

NOMINAL LENGTH [FT]	OVERALL LENGTH - L [IN]	DAISY CHAIN
1	12.10	DN
1.25	15.10	DN
1.5	18.10	DN
1.75	21.10	DN
2	24.10	DY / DN
2.25	27.10	DN
2.5	30.10	DN
2.75	33.10	DN
3	36.10	DN
3.25	39.10	DN
3.5	42.10	DN
3.75	45.10	DN
4	48.10	DY / DN
4.25	51.10	DN
4.5	54.10	DN
4.75	57.10	DN
5	60.10	DN
5.25	63.10	DN
5.5	66.10	DN
5.75	69.10	DN
6	72.10	DY / DN

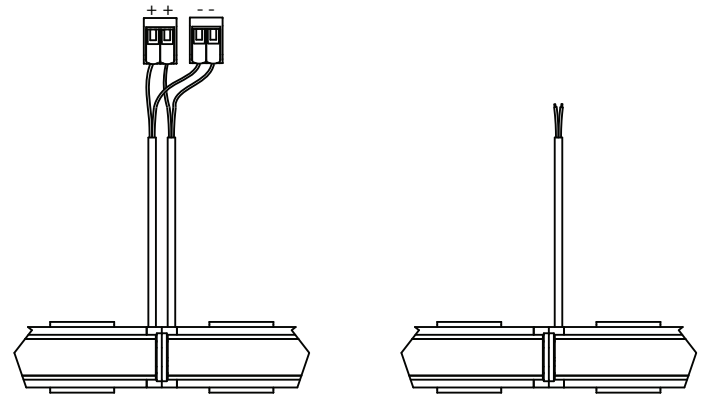

**DY** - YES DAISY CHAIN    **DN** - NO DAISY CHAIN

REQUIRES REMOTE DRIVER  
(REF.XBOX OPTIONS)

\*SINGLE DRIVER RUNS UP TO 8FT MAX.

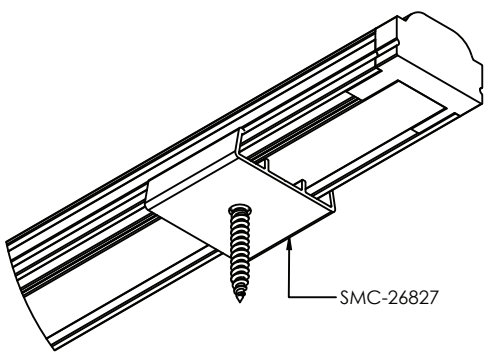
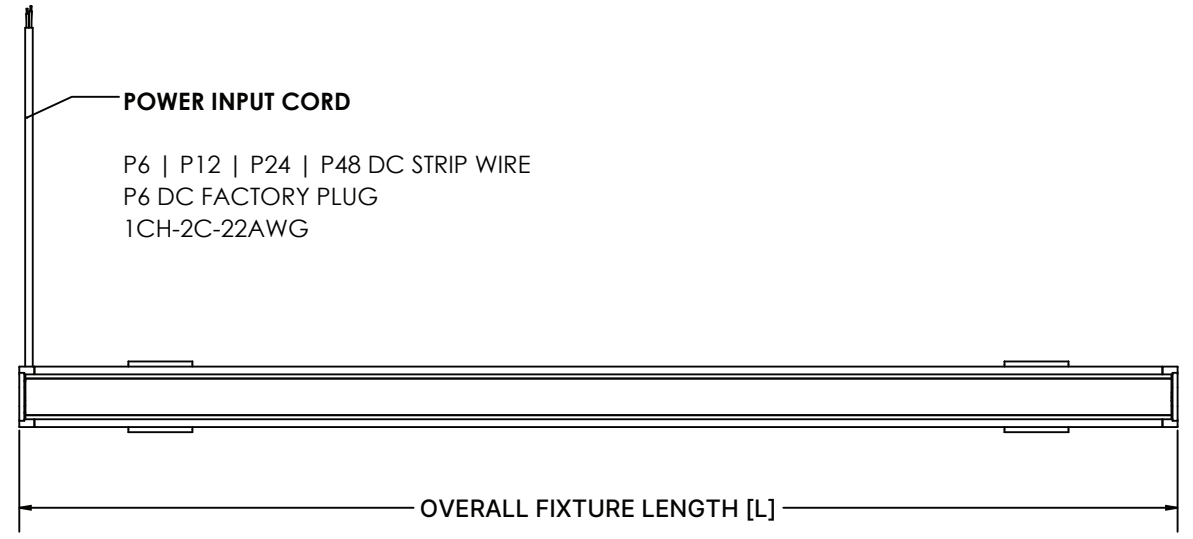

**SMC** - SURFACE MOUNT CLIP

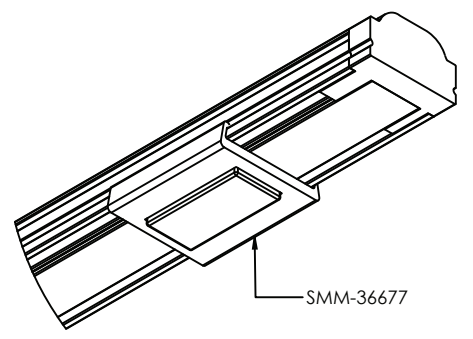

**SMM** - SURFACE MOUNT MAGNET

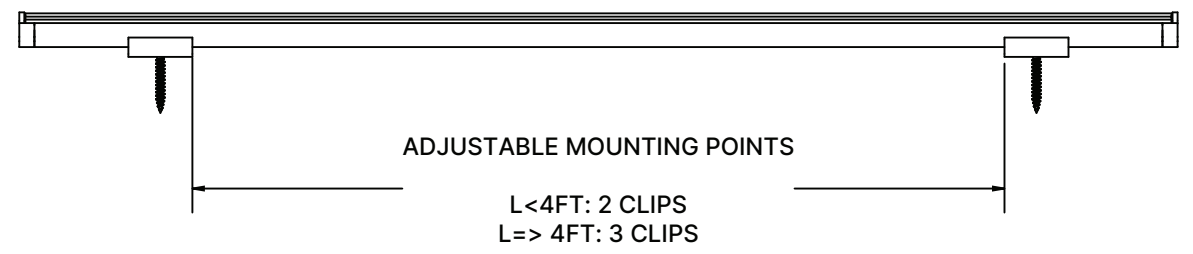
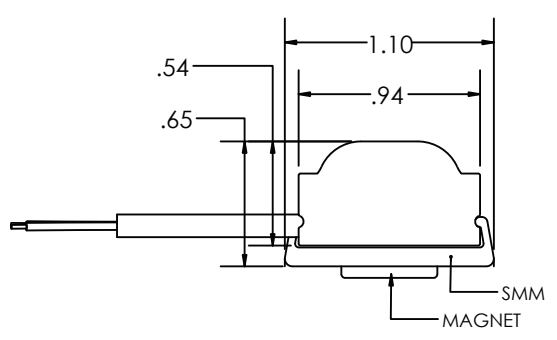
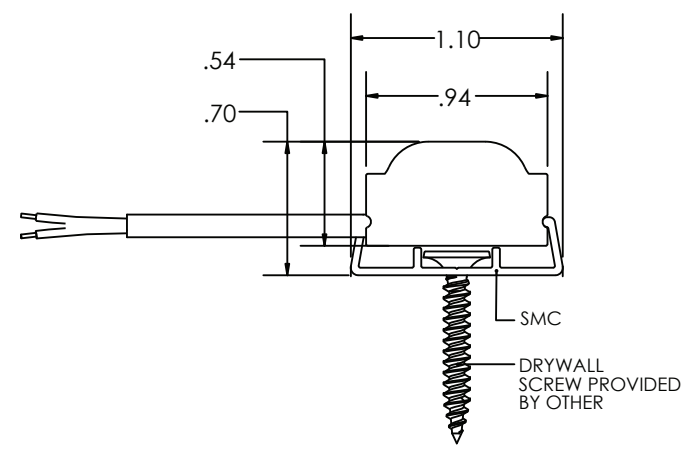

PROPRIETARY AND CONFIDENTIAL: THE INFORMATION CONTAINED IN THIS DRAWING IS THE SOLE PROPERTY OF XICO. ANY REPRODUCTION IN PART OR AS A WHOLE WITHOUT THE WRITTEN PERMISSION OF XICO IS PROHIBITED.

NOTES		SERIES NANO	PRODUCT NAME NANORAIL95	TYPE RAIL	MOUNTING SMC   SMM	LENGTH STD	PRODUCT CODE NRA95-S	
		DWG NUMBER NRA95-S-PROD-TECH	MASTER ASSEMBLY FOA02-36484-1-6-CO-SMC-SW	DATE 08/02/2024	SCALE 1:8	SHEET 1 OF 3	REV A	

19 WHEELING AVENUE | WOBURN, MA 01801 | XICOLED.COM

NOMINAL RUN LENGTH [FT]	OVERALL RUN LENGTH - L [IN]	RUN LENGTH BREAKDOWN	DRIVER QTY PER RUN
7	84.2	4 + 3	1
8	96.2	4 + 4	1
9	108.2	5 + 4	2
10	120.2	6 + 4	2
11	132.2	6 + 5	2
12	144.2	6 + 6	2
13	156.3	4 + 4 + 5	2
14	168.3	4 + 4 + 6	2
15	180.3	4 + 4 + 4 + 3	2
16	192.4	4 + 4 + 4 + 4	2
17	204.4	4 + 4 + 4 + 5	2
18	216.5	4 + 4 + 4 + 4 + 2	3
19	228.5	4 + 4 + 4 + 4 + 3	3
20	240.5	4 + 4 + 4 + 4 + 4	3
21	252.5	4 + 4 + 4 + 4 + 5	3
22	264.6	4 + 4 + 4 + 4 + 4 + 2	3
23	276.6	4 + 4 + 4 + 4 + 4 + 3	3
24	288.6	4 + 4 + 4 + 4 + 4 + 4	3
25	300.6	4 + 4 + 4 + 4 + 4 + 5	4
26	312.7	4 + 4 + 4 + 4 + 4 + 4 + 2	4
27	324.7	4 + 4 + 4 + 4 + 4 + 4 + 3	4
28	336.7	4 + 4 + 4 + 4 + 4 + 4 + 4	4
29	348.7	4 + 4 + 4 + 4 + 4 + 4 + 5	4
30	360.8	4 + 4 + 4 + 4 + 4 + 4 + 4 + 2	4
FORMULA TO CALCULATE LONGER RUNS	OVERALL RUN LENGTH [IN] = NOMINAL (FT)X12 + ROUNDUP(NOMINAL (FT)/4) * 0.10	DRIVER COUNT IS BASED ON DAISY-CHAIN CONFIGURATION. IF FIXTURES CANNOT BE DAISY-CHAINED AND REQUIRE INDEPENDENT WIRING, A 1:1 DRIVER-TO-FIXTURE RATIO WILL APPLY	
THESE DIMENSIONS HAVE BEEN CALCULATED ASSUMING A LINEAR RUN WITH NO GAP BETWEEN FIXTURES, WITH FIXTURES INSTALLED END-TO-END. IF FIXTURES ARE INSTALLED WITH SPACING BETWEEN THEM, THIS ADDITIONAL GAP MUST BE TAKEN INTO ACCOUNT			
CUSTOM RUN			

### REMOTE DRIVERBOX OPTIONS

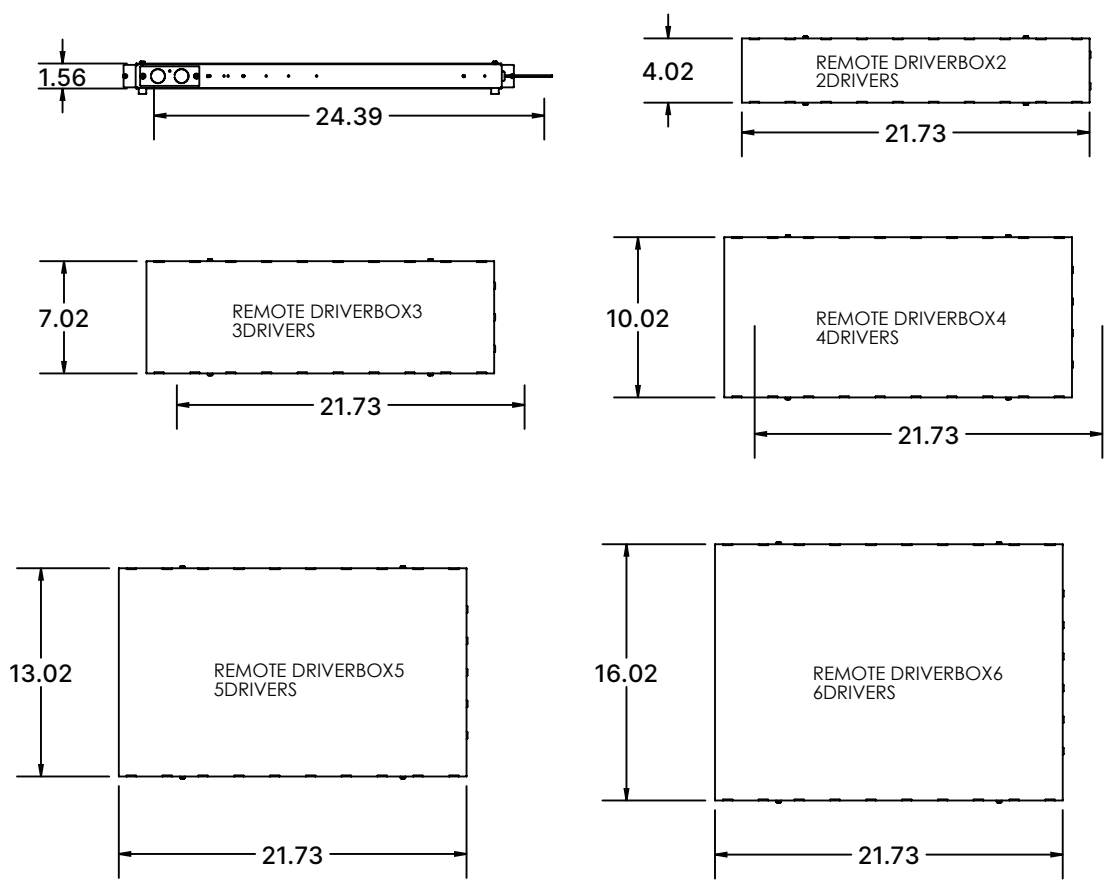

REQUIRES REMOTE DRIVER (REF.XBOX OPTIONS)

\*SINGLE DRIVER RUNS UP TO 8FT MAX.

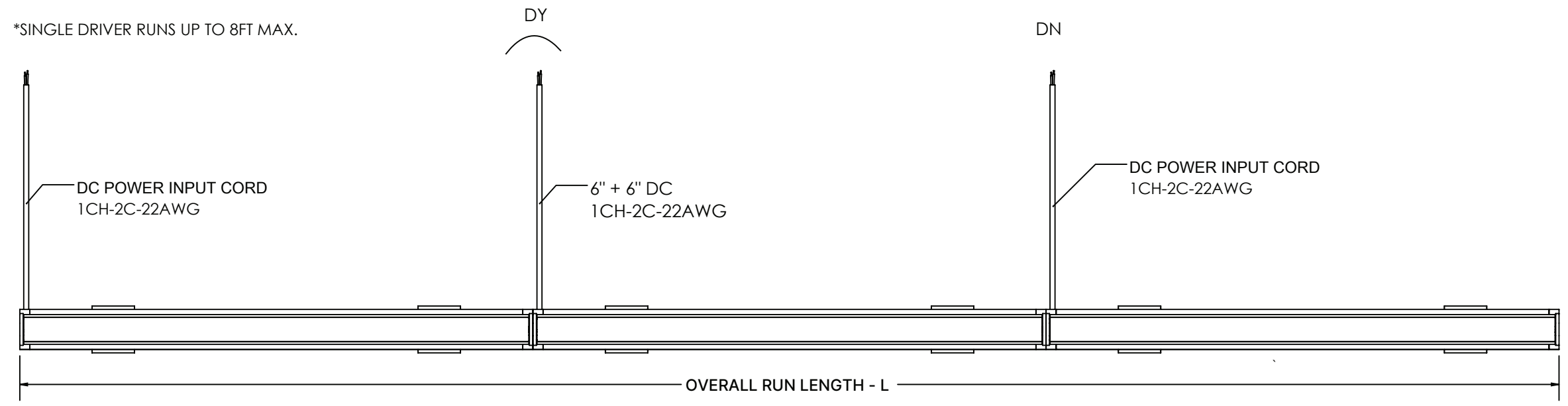

PROPRIETARY AND CONFIDENTIAL : THE INFORMATION CONTAINED IN THIS DRAWING IS THE SOLE PROPERTY OF XICO. ANY REPRODUCTION IN PART OR AS A WHOLE WITHOUT THE WRITTEN PERMISSION OF XICO IS PROHIBITED.

NOTES		SERIES NANO	PRODUCT NAME NANORAIL95	TYPE RAIL	MOUNTING SMC   SMM	LENGTH RUN	PRODUCT CODE NRA95-S	
		DWG NUMBER NRA95-S-PROD-TECH	MASTER ASSEMBLY FOA02-36484-1-6-CO-SMC-SW	DATE 08/02/2024	SCALE 1:8	SHEET 1 OF 3	REV A	

19 WHEELING AVENUE | WOBURN, MA 01801 | XICOLED.COM