

MICRODash Pendant

High-Performance Linear LED





Integral Driver



MICRODash Pendant

MICRODash Series

Warnings

-  Risk of fire and electrical shock
-  Turn off power at breaker
-  Installation requires knowledge of electrical systems and should be installed by a qualified electrician. If not qualified, **DO NOT ATTEMPT INSTALLATION.**

Care Instructions

-  Wipe with a soft cloth only
-  Always avoid using harsh chemicals and/or cleaners

STEP 1 — Placement

Mark hole locations on the installation surface matching locations of the mounting hardware. Adjust cables to desired length and cut if needed.

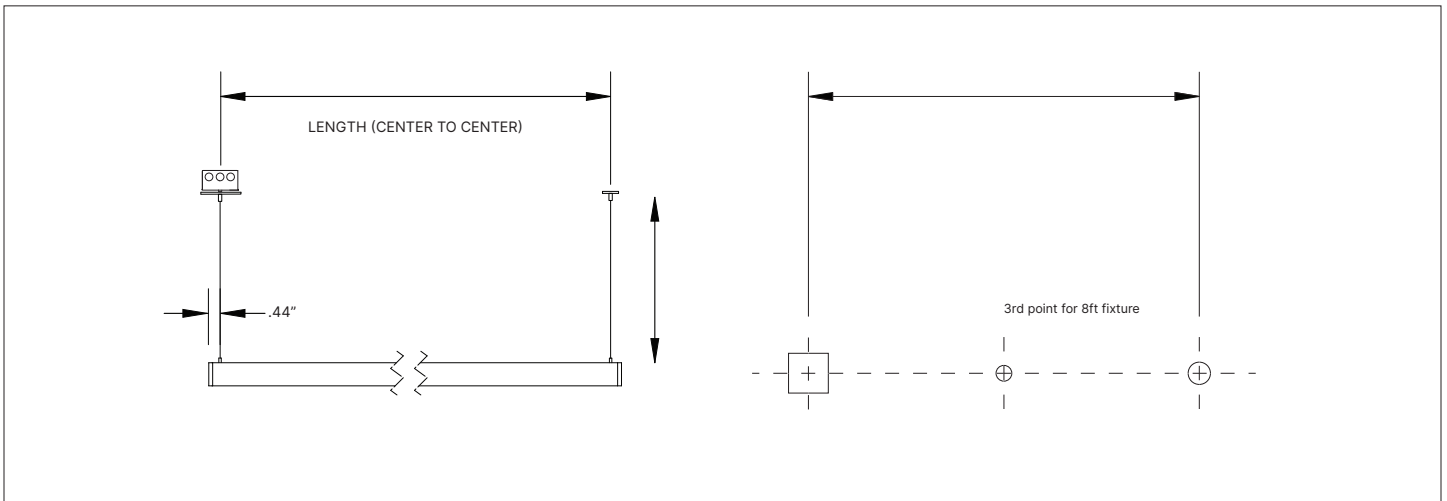

Designed & Built in
BOSTON

Declare



STEP 2 — Hang Hardware Connection

Fasten the Aircraft Grippers to the fixture.

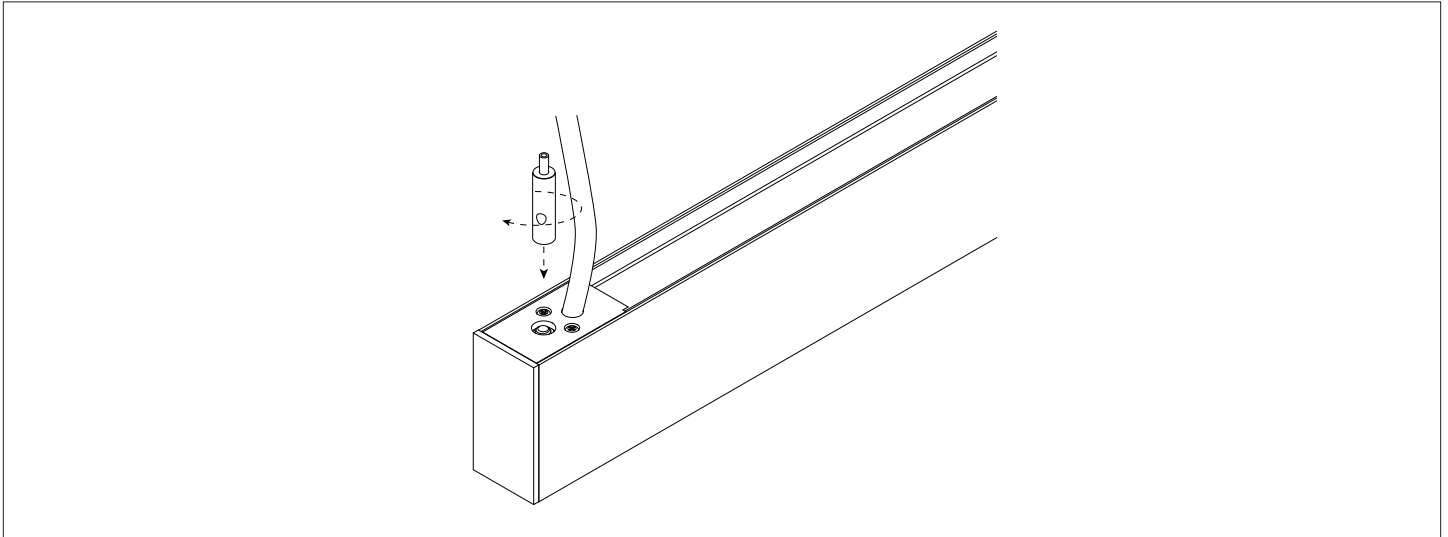

STEP 3 — Junction Box Connection

Attach the Aircraft cable to the Grippers. Feed the AC and Aircraft cables through the canopy and connect to the Junction box. Refer to the wiring diagram.

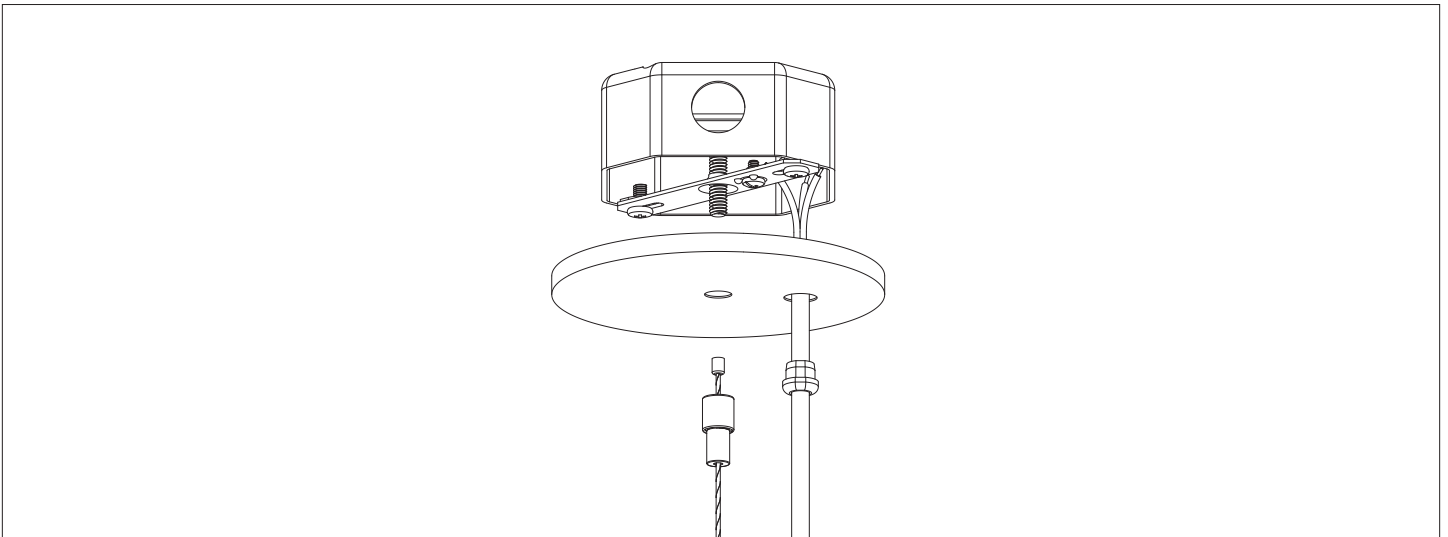

STEP 4 — Spacing

Fasten the non-power end of the fixture to the mounting surface using the hardware rated for your application.

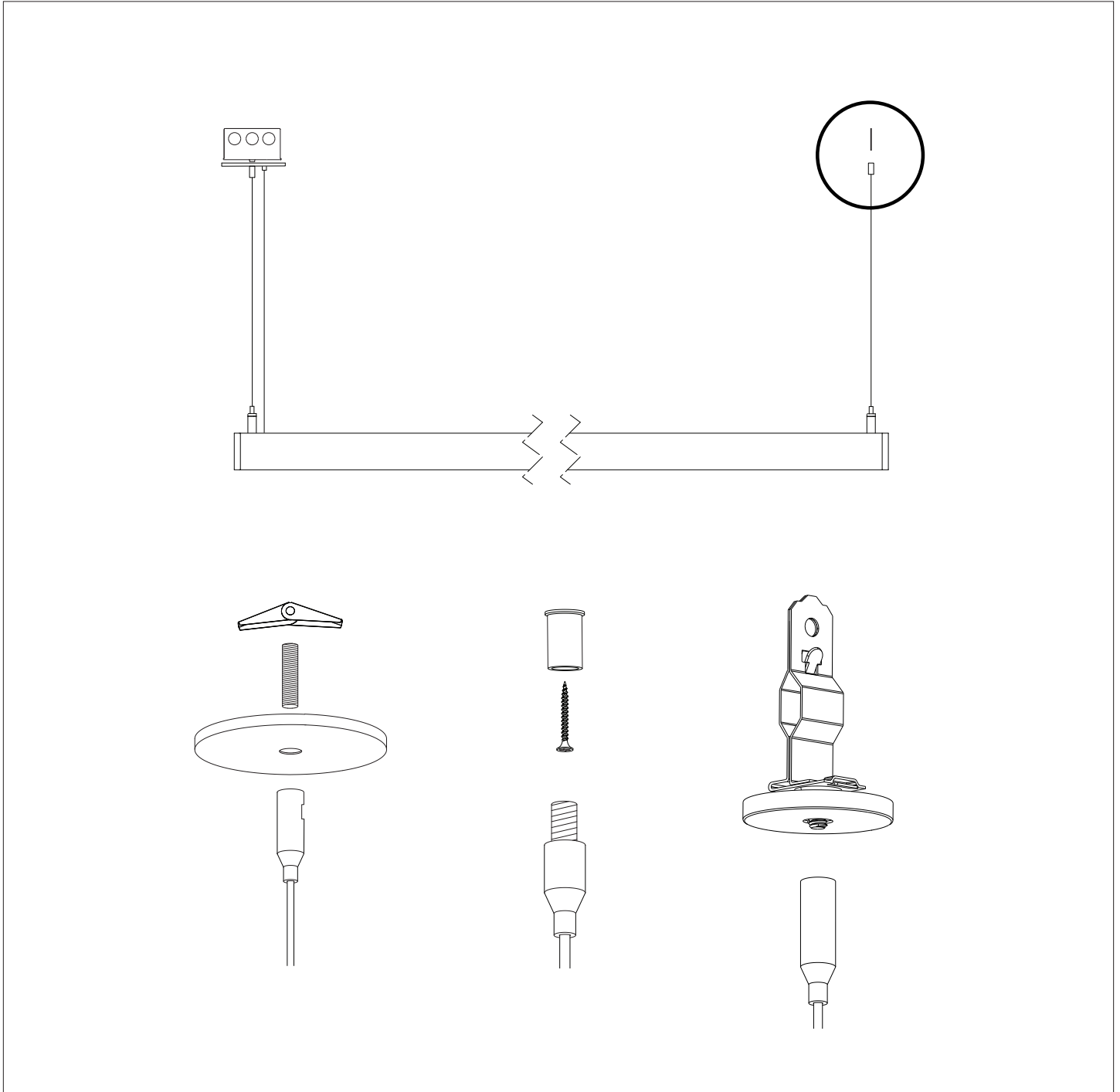

Care Instructions:

Wipe with a soft cloth only. Always avoid using harsh chemicals and/or cleaners.

CONTINUOUS RUN - STEP 1 — Hang Hardware Connection

Raise powered end fixture (with joiner) to jbox and secure to mounting surface. Do not fully tighten the cable gripper at the joiner (open end).

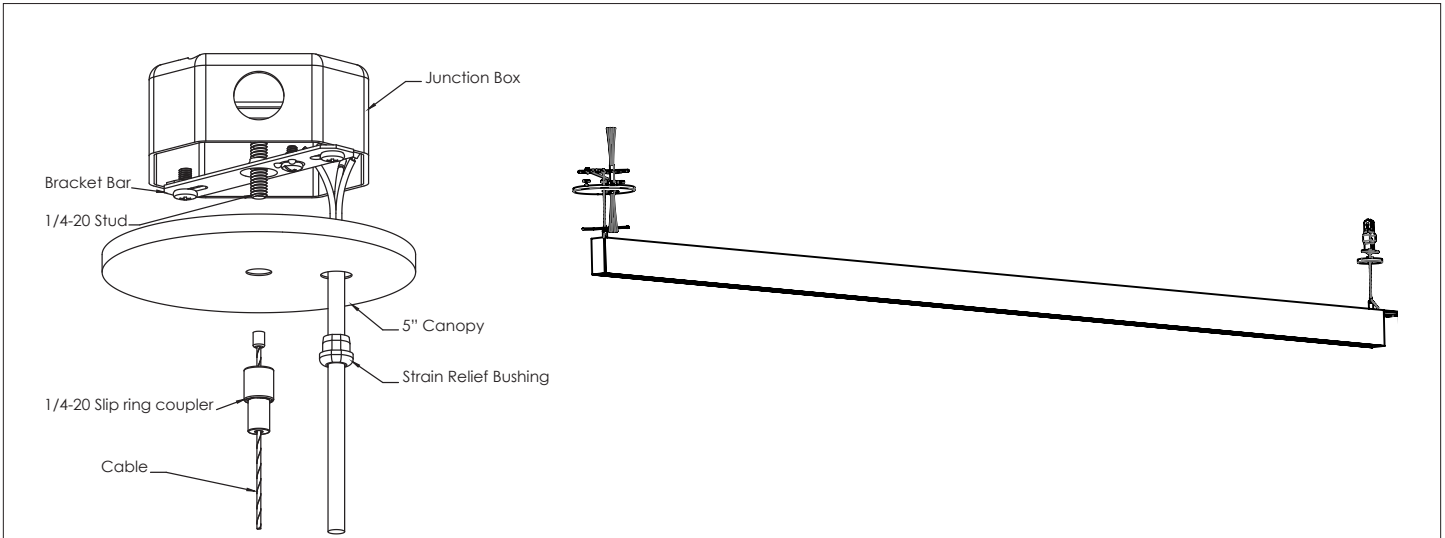

STEP 2 — Connect Fixtures

Attach the Aircraft cable to the Grippers. Feed the AC and Aircraft cables through the canopy and connect to the Junction box. Refer to the wiring diagram.

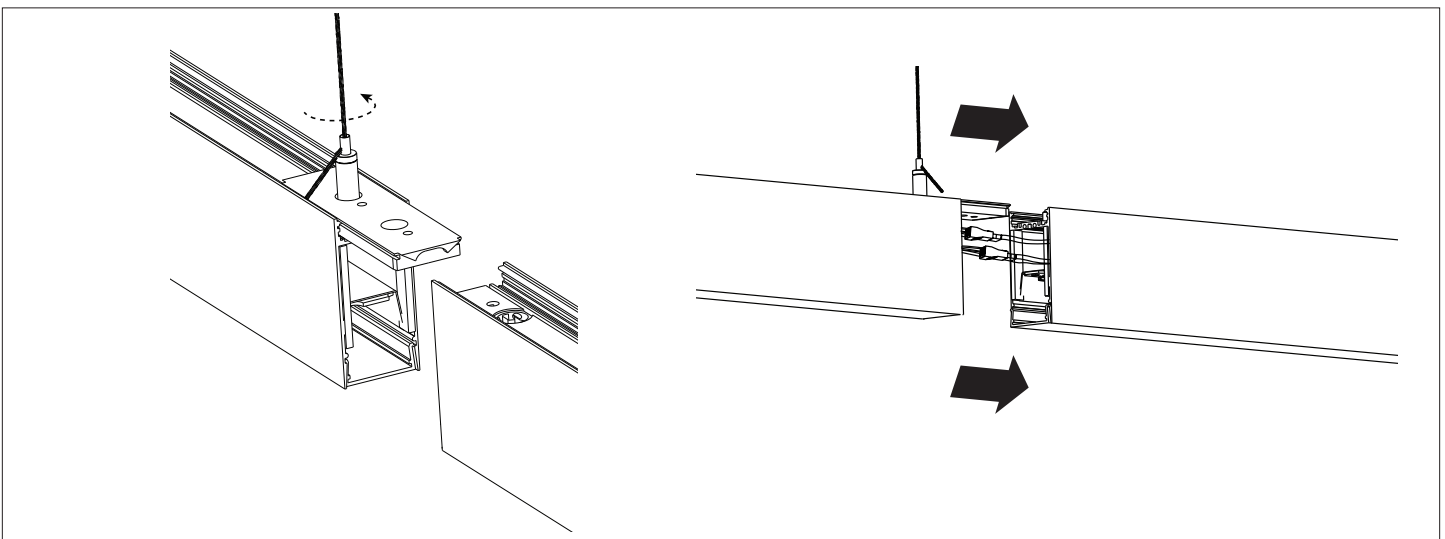

STEP 4 — Spacing

Fully assembled fixture

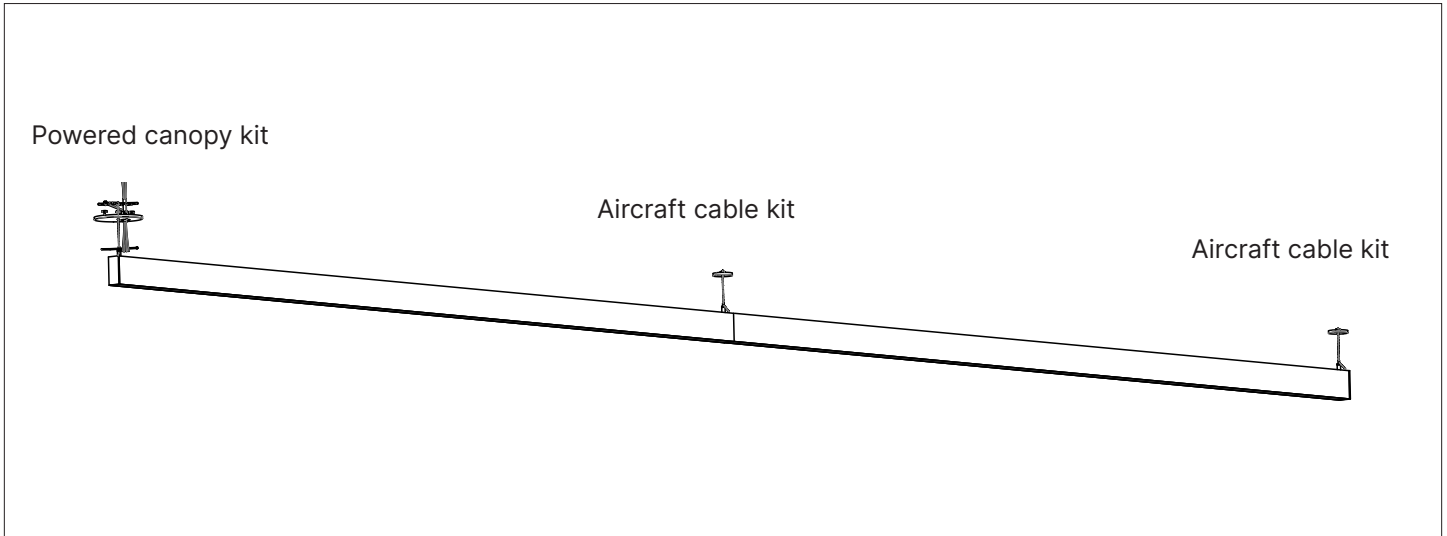

STEP 5 — Connect Fixtures

Snap the lens(es) into fixture body.

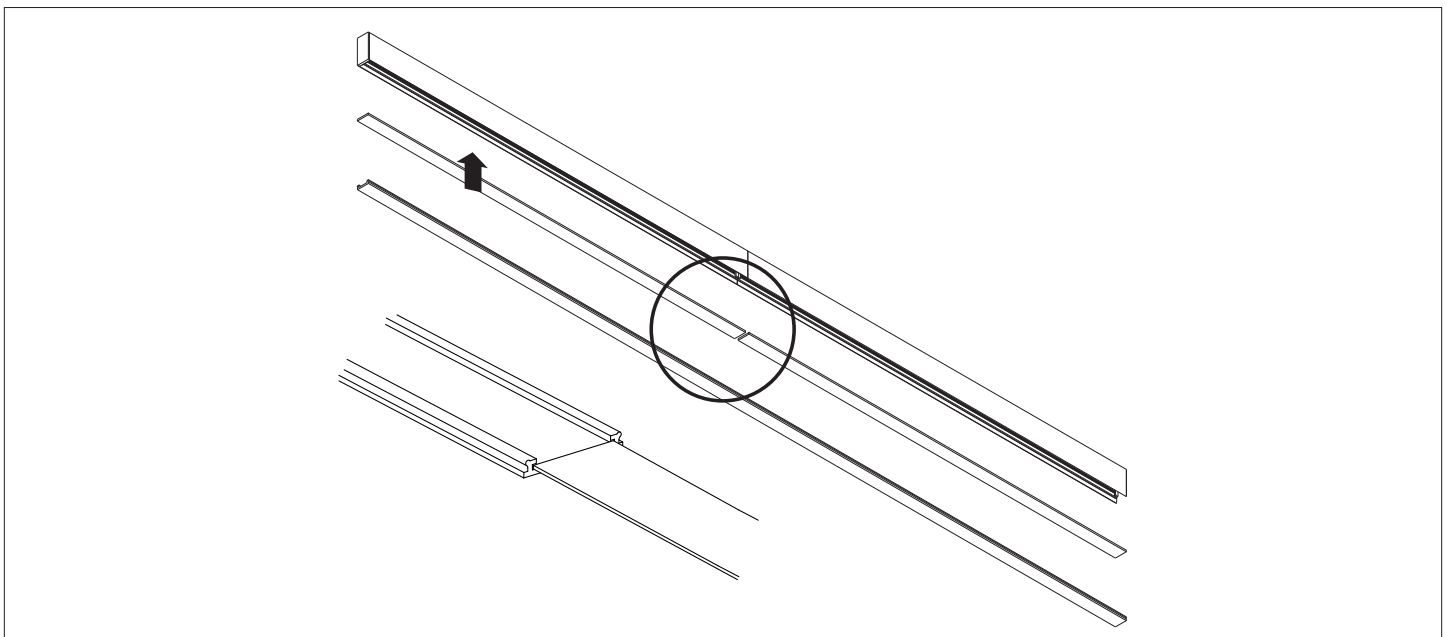

Care Instructions:

Wipe with a soft cloth only. Always avoid using harsh chemicals and/or cleaners.

Wiring Guide

Wire the Power Feed End to the J-Box.

