

# NANOSquare Wall

## High-Performance Linear LED

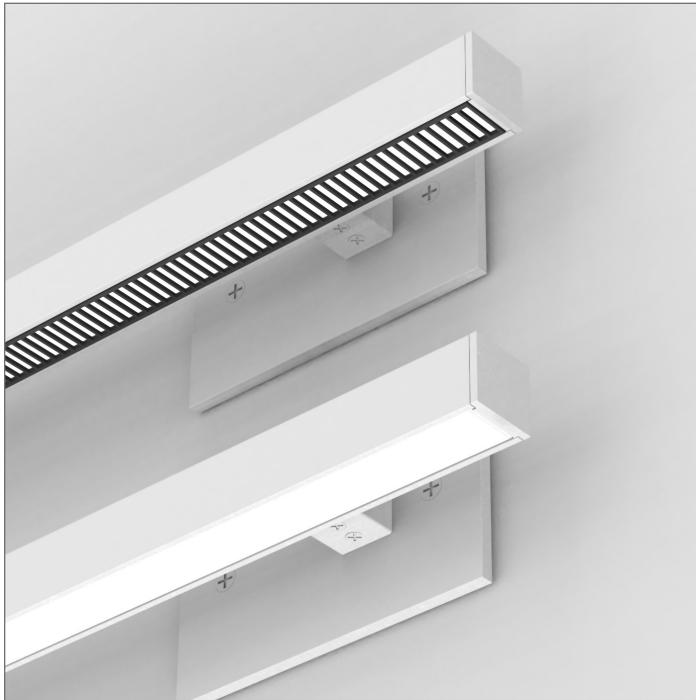



Integral Driver



### NANOSquare Wall

NANOSquare

#### Warnings

-  Risk of fire and electrical shock
-  Turn off power at breaker
-  Installation requires knowledge of electrical systems and should be installed by a qualified electrician. If not qualified, **DO NOT ATTEMPT INSTALLATION.**

#### Care Instructions

-  Wipe with a soft cloth only
-  Always avoid using harsh chemicals and/or cleaners

## STEP 1 — Mounting Preparation

Backplates are not adjustable. Use rectangular single gang electrical boxes, installed horizontally. Hold the NANOSquare fixture up to the wall and check to make sure canopies and mounting hardware are properly spaced on the mounting surface for final installation.

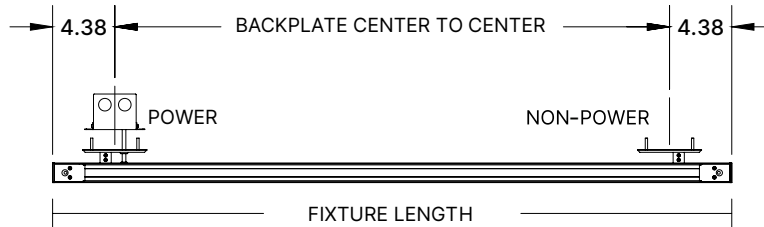

Designed & Built in  
**BOSTON**

**Declare**



## STEP 2 — Install Driver Box

Feed the Power Cable from the fixture through the Backplate Assembly and make the DC wire connections. Refer to the Wiring Diagram.

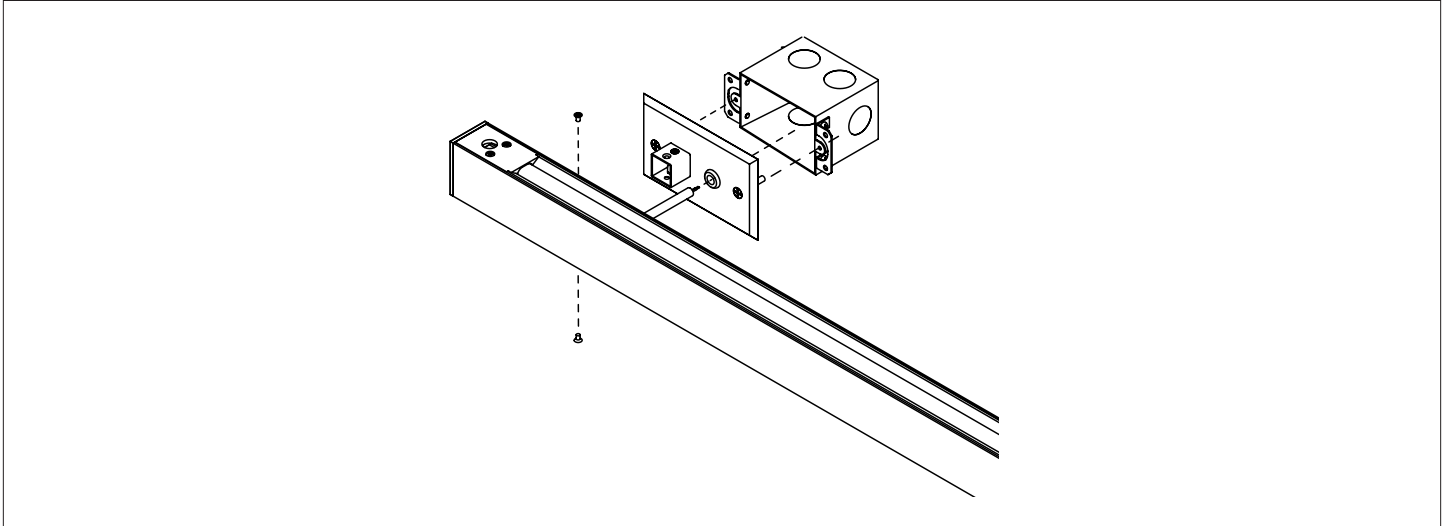

## STEP 3 — Secure Backplate

Secure the Backplate Assembly to the electrical box while feeding the power cable through the Backplate Engage both projection arms with the brackets located on the NANOSquare fixture and secure with provided screws.

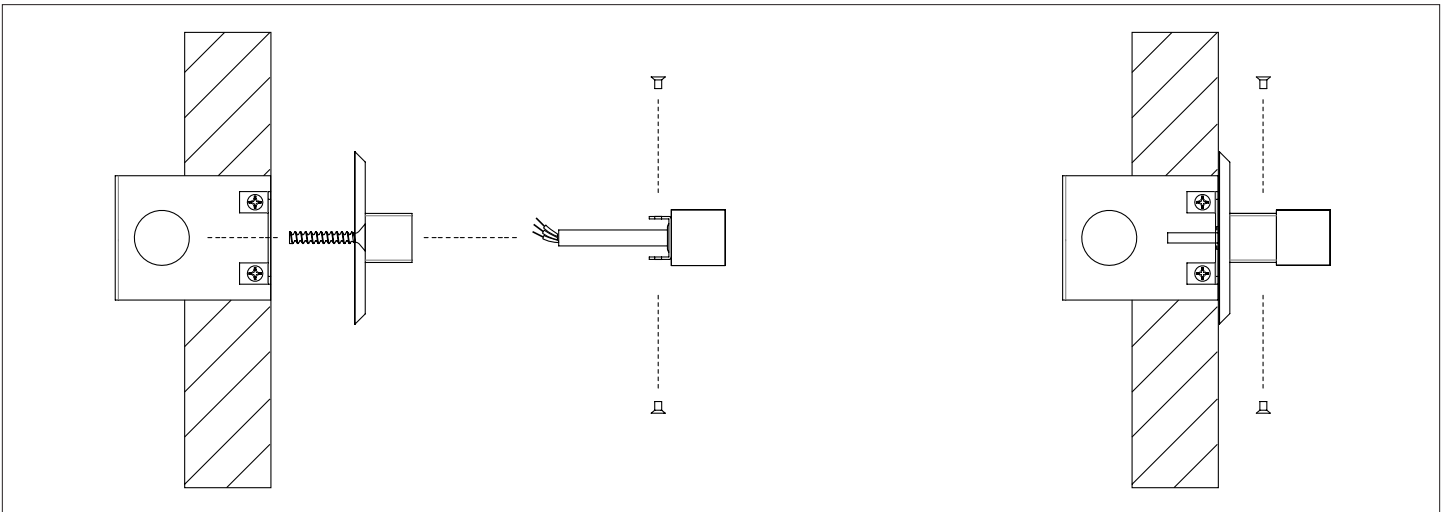

## STEP 4 — Final Installation

Depending on your NANOSquare fixture specifications, there may be the need for (2) electrical boxes. Follow Step 2-3 for each mounting location if needed. Connect power to the Driver Box.

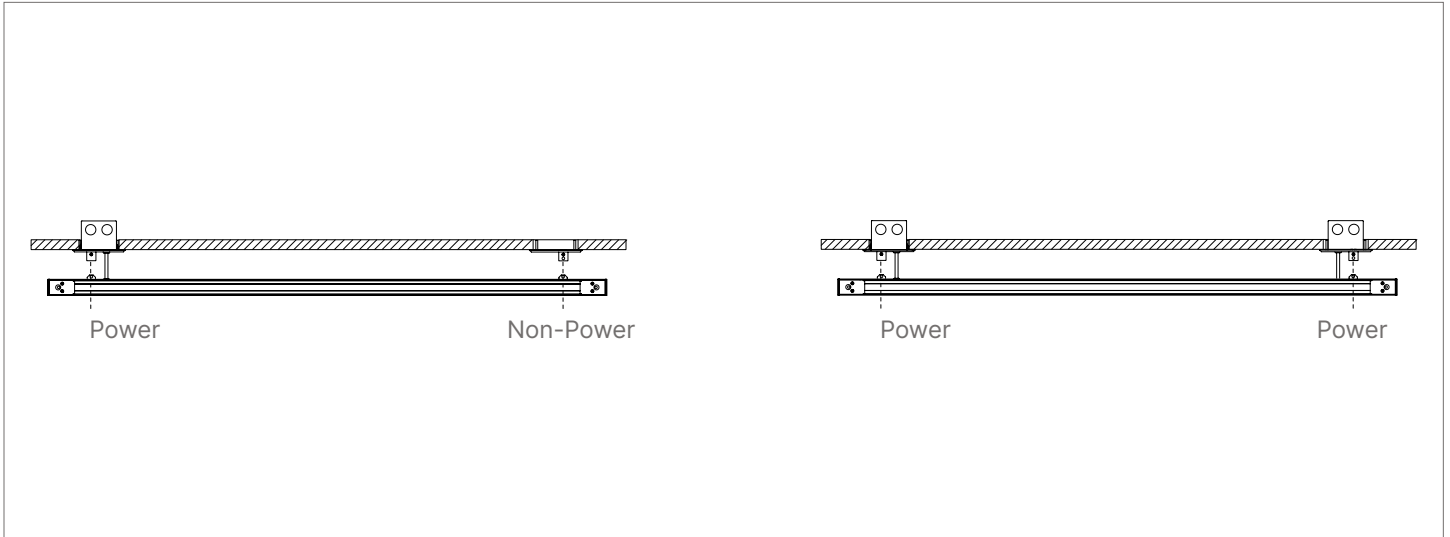

## NANOSquare Wall Continuous Run

### STEP 1 — Engage Joiner Bracket and Light Sealer

Engage the NANOSquare fixtures together by sliding the Joiner Bracket and Light Sealer into the second fixture. The Joiner Bracket and Light Sealer come fully assembled.

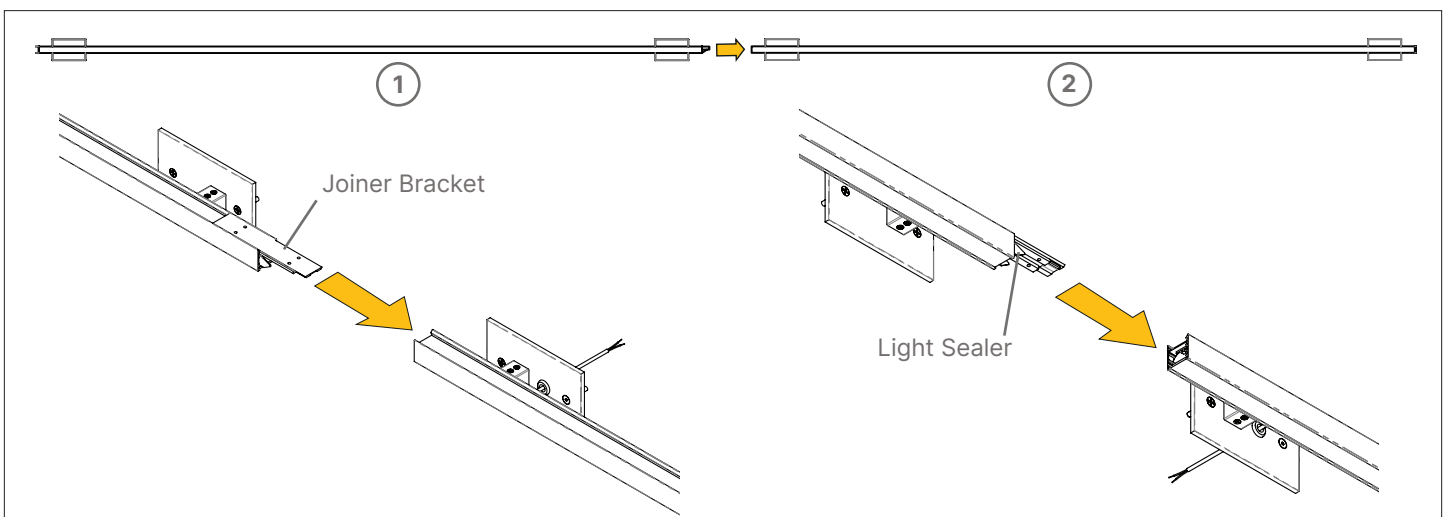

## STEP 2 — Runs Assembled Together

The Joiner Bracket and Light Sealer are fully engaged. Fasten Joiner Bracket with appropriate hardware. Repeat previous step depending on the number of fixtures in your assembly.

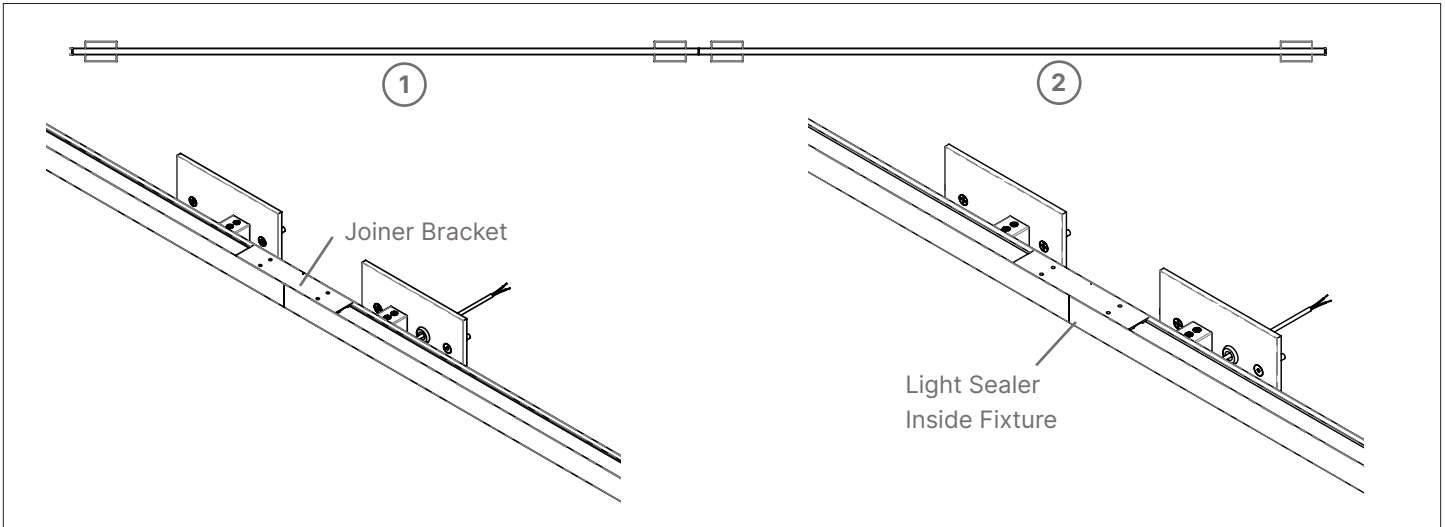

## STEP 3 — Mounting NANOSquare Fixture

Mount NANOSquare fixture to wall with provided Wall Mount Kit. Refer to previous pages on how to mount fixtures to wall. Refer to step 4 for connecting power.

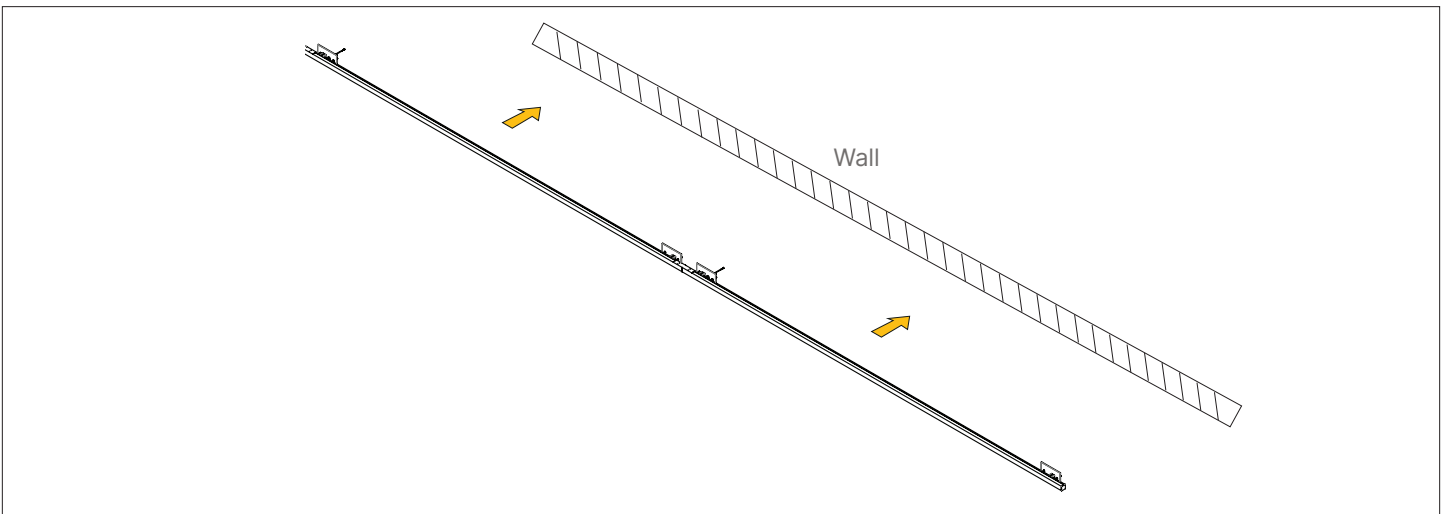

### Wiring Guide

Wire the Power Feed End to the J-Box and secure the Canopy to the J-Box or Power Source.

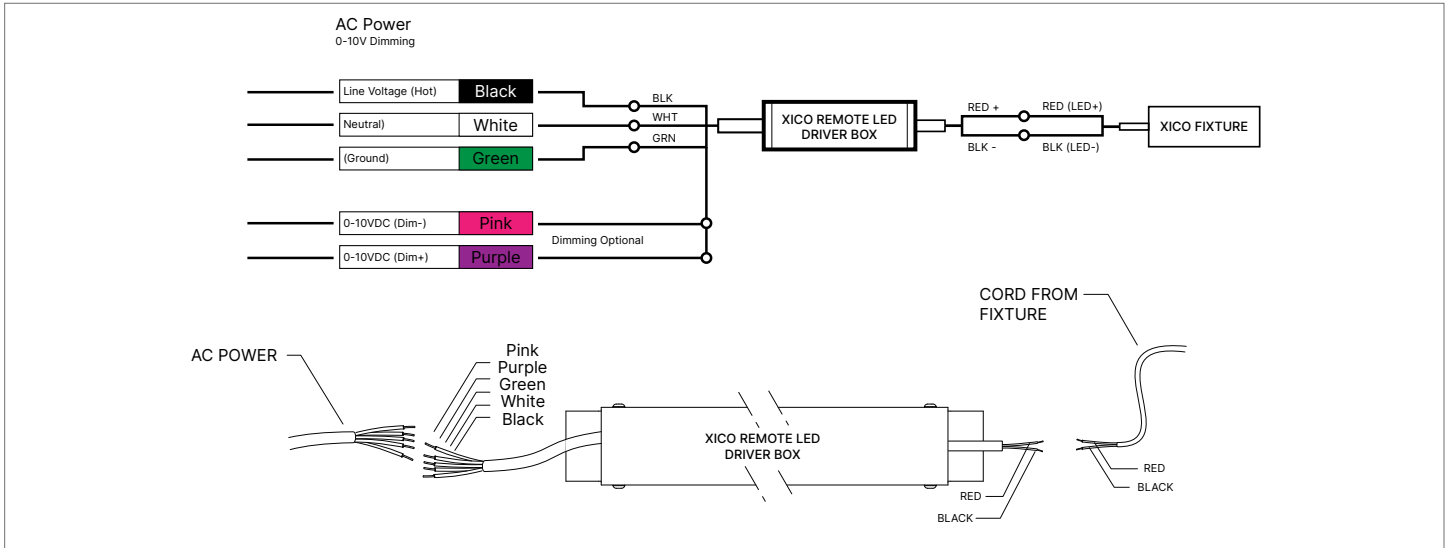

# Voltage Drop

## 24 VDC and Wire Length Chart (Driver to Fixture)

### XICO LED Fixture with Remote Drivers

When installing a XICO fixture with a remote driver and the distance is a long way from the fixture, it is important to properly specify the correct wire gauge (AWG/ or thickness of wire) for the distance of wire required. The maximum remote mounting distance is a function of the total voltage-drop across the output of the LED Driver.

### How to Use the Chart

- Step 1:** Calculate the total wattage of the LED lighting system (round up to the nearest 10 W).
- Step 2:** Find the wattage in the top row and follow the column down to maximum length (round up) of wiring between the LEDs and the power supply.
- Step 3:** Look to the left column for the wire gauge size required to prevent voltage drop over 3%.

Maximum Cable Length from Remote Driver to Fixture — 24 VDC Driver										
Wire Gauge	Total Fixture Wattage (W)									
	10 W	20 W	30 W	40 W	50 W	60 W	70 W	80 W	90 W	100 W
18 AWG	134 ft	68 ft	45 ft	33 ft	27 ft	22 ft	19 ft	17 ft	15 ft	14 ft
16 AWG	215 ft	109 ft	72 ft	54 ft	43 ft	36 ft	31 ft	27 ft	24 ft	22 ft
14 AWG	345 ft	174 ft	115 ft	86 ft	69 ft	57 ft	49 ft	43 ft	39 ft	36 ft
12 AWG	539 ft	272 ft	181 ft	135 ft	108 ft	90 ft	77 ft	68 ft	62 ft	56 ft
10 AWG	784 ft	397 ft	263 ft	197 ft	158 ft	131 ft	112 ft	98 ft	95 ft	82 ft

### Remote Driver to Fixture Example

**Calculate total load**

An 8 ft fixture using 4 W/ft requires a total of 32 W. Round up to the nearest load of 40 W.

**Find distance from driver to Load**

Let's assume the distance is 40 ft from the driver to the fixture. Round up to the nearest distance of 54 ft.

**Choose wire gauge**

It's recommended to install 16 AWG wire between the driver and fixture to eliminate noticeable voltage drop.