

# MICROSquare Surface

## High-Performance Linear LED



### MICROSquare Surface

MICROSquare Series

#### Warnings

- Risk of fire and electrical shock
- Turn off power at breaker
- Installation requires knowledge of electrical systems and should be installed by a qualified electrician. If not qualified, **DO NOT ATTEMPT INSTALLATION.**

#### Care Instructions

- Wipe with a soft cloth only
- Always avoid using harsh chemicals and/or cleaners

Proceed to Page 4 for MICROSquare Surface Mount TBar Instructions

### STEP 1 — Mounting Clip Placement MICROSquare Surface Mount

Mounting clips are adjustable. Locate a secured stud when possible for each bracket and mark the locations.

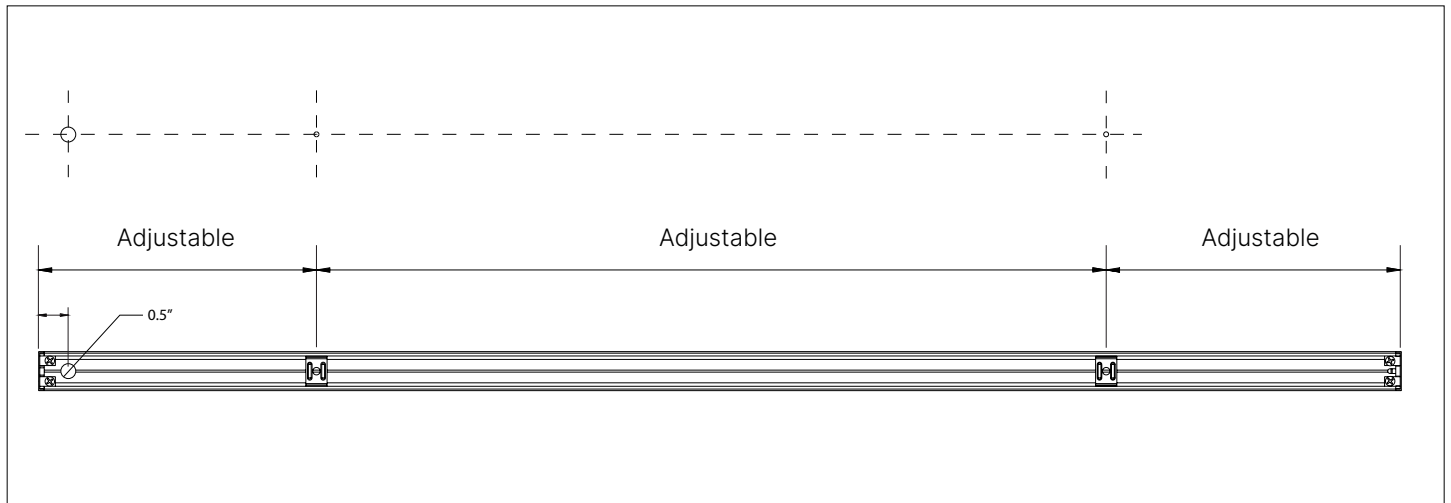

Designed & Built in  
**BOSTON**

**Declare**



**STEP 2 — Secure Mounting Clips** MICROSquare Surface Mount

Secure the Mounting Clips to the mounting surface with the appropriate hardware.

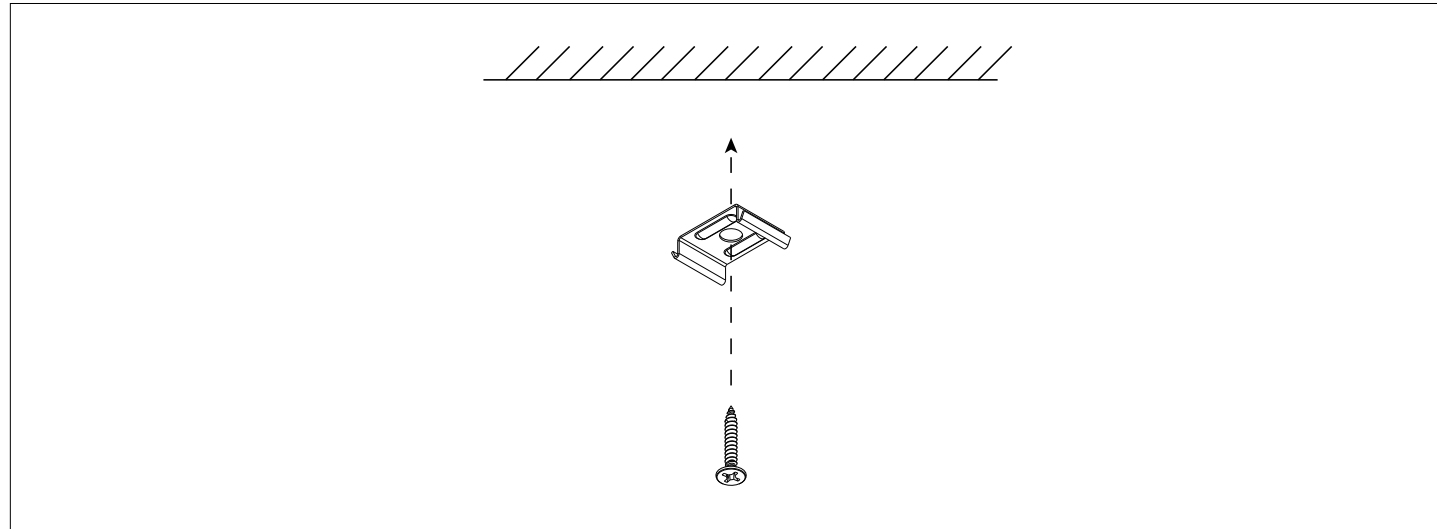

**STEP 3 — Install Remote Driver Box** MICROSquare Surface Mount

Install the Remote Driver Box. Raise the MICROSquare fixture to the mounting surface and connect the wires to an approved power source or Driver Box. Refer to the wiring diagram.

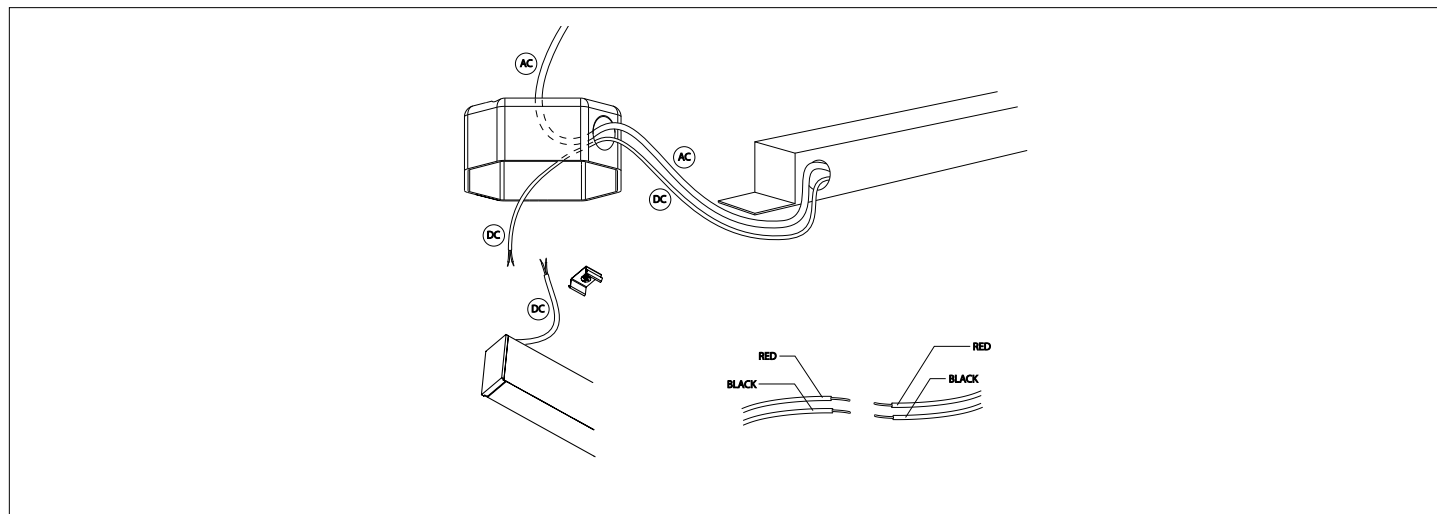

**STEP 4 — Fixture Mounting** MICROSquare Surface Mount

Raise the MICROSquare fixture and engage the Mounting Clips. The fixture will click when properly seated.

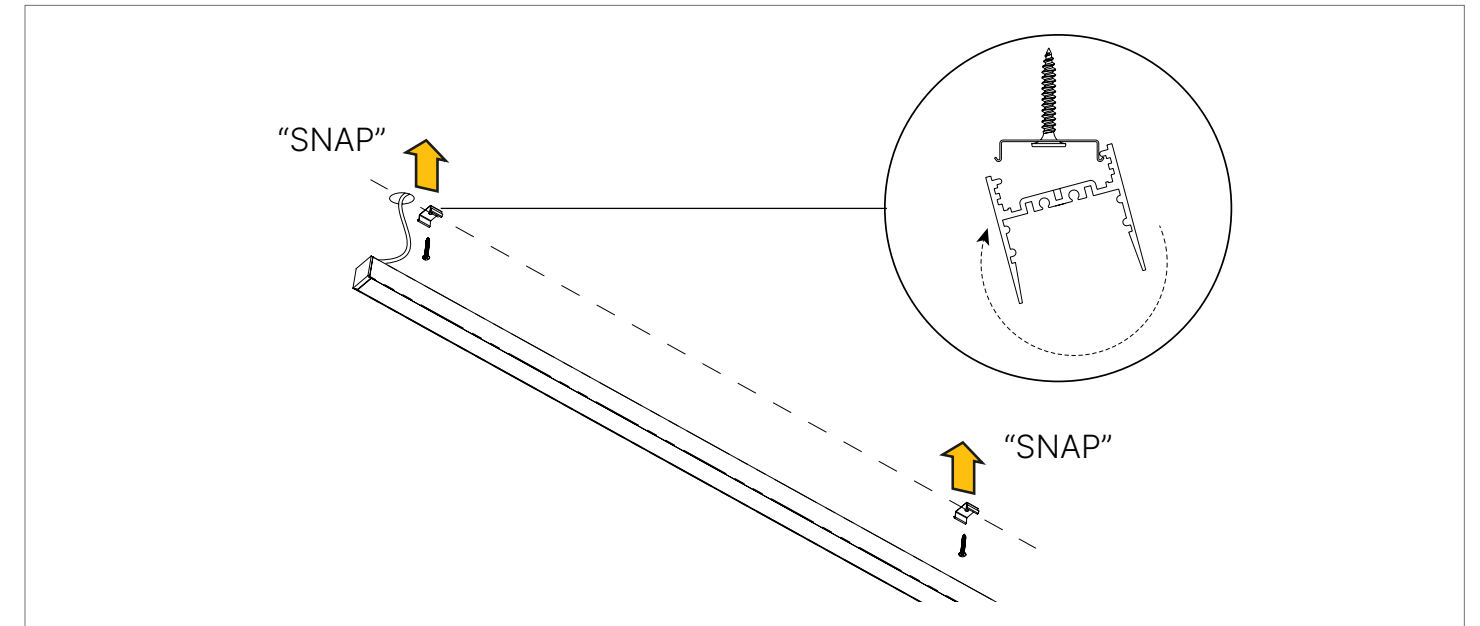

**STEP 5 — Final Installation** MICROSquare Surface Mount

Restore power.

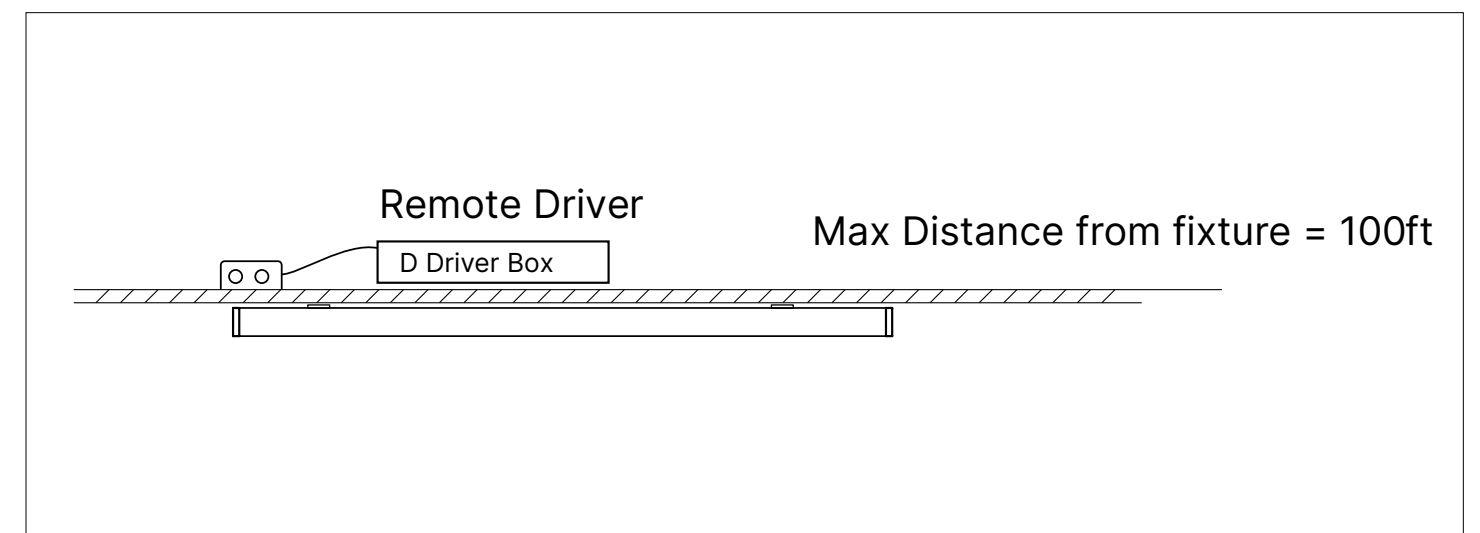

**STEP 1 — TBar Clips** MICROSquare Surface Mount TBar

The MICROSquare fixture comes fully assembled with TBar Clips for your grid ceiling framework, if specified.

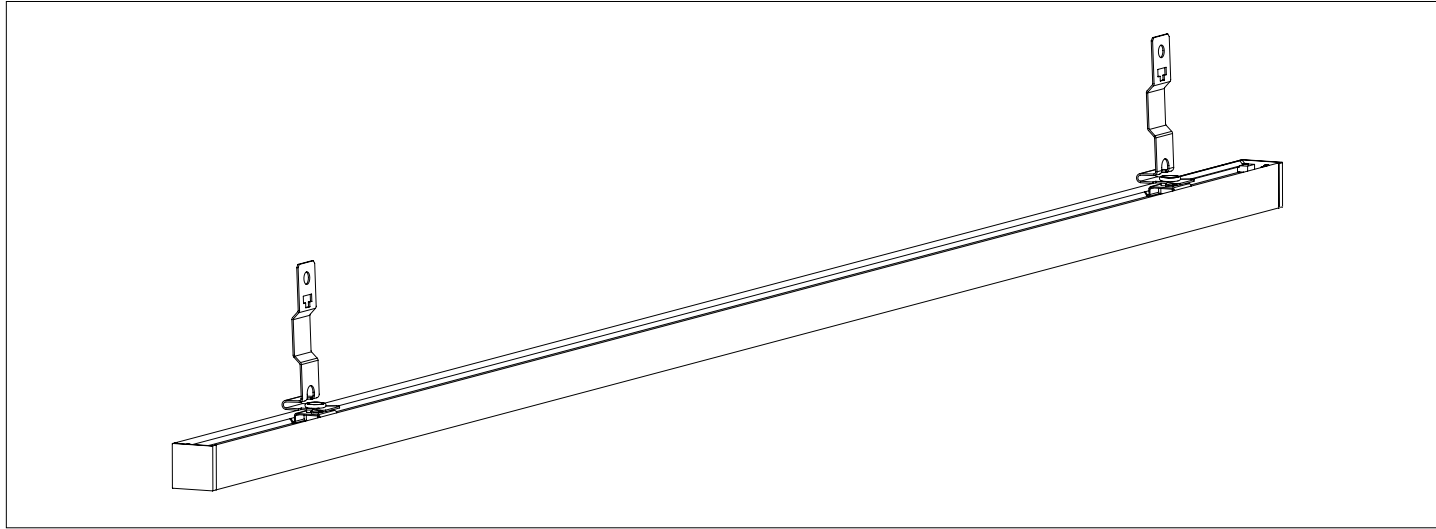
**STEP 2 — Location on TBar** MICROSquare Surface Mount TBar

Bring the MICROSquare fixture up to the desired location on the TBar. Allow wires to pass through framework.

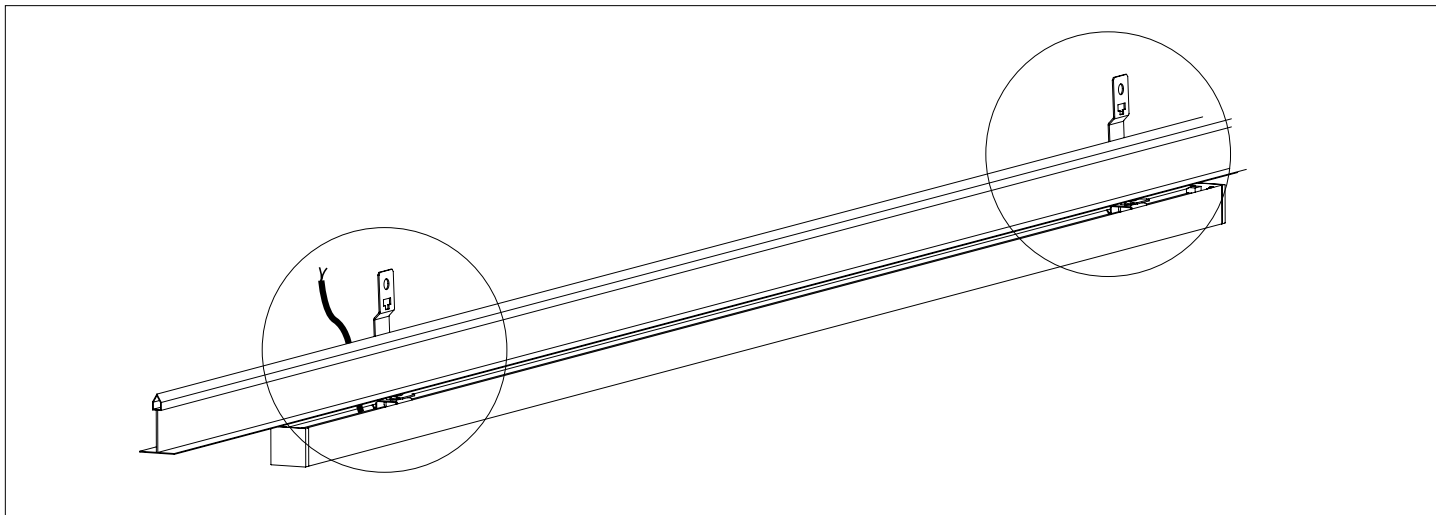
**STEP 3 — Fixture Mounting** MICROSquare Surface Mount TBar

Engage the TBar clips by inserting the loose clip below the clip base that is mounted to the MICROSquare fixture. The clips will SNAP when fully engaged.

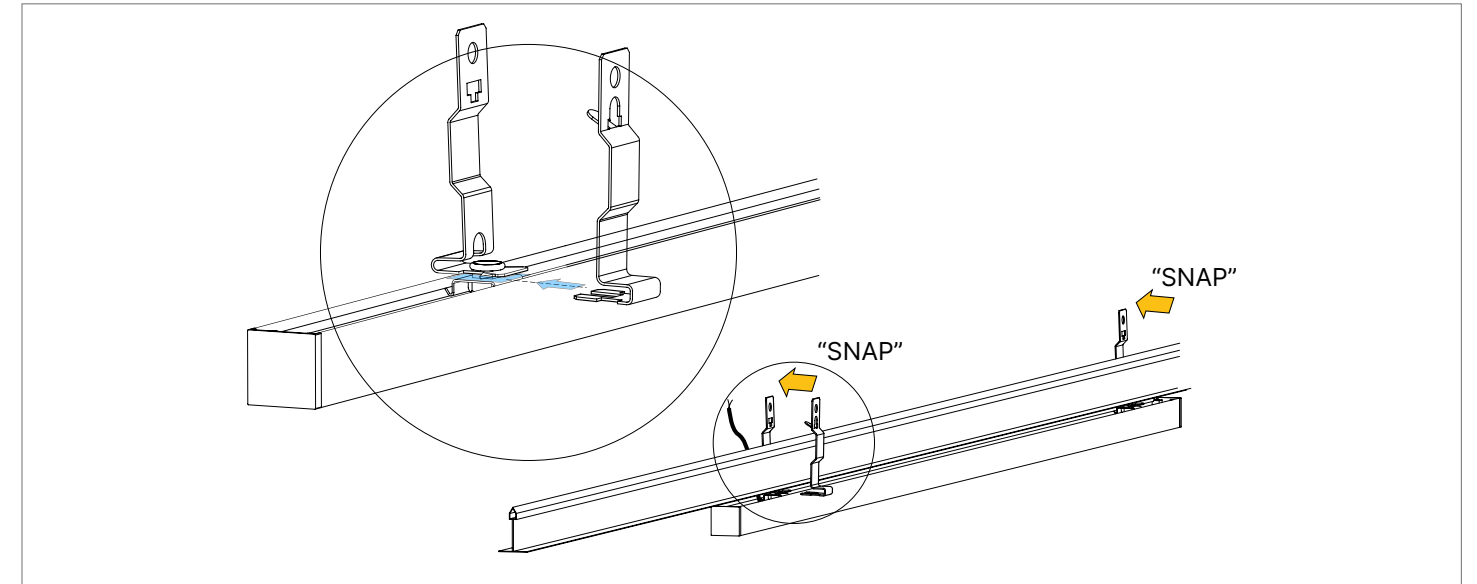
**STEP 4 — Secure to Support** MICROSquare Surface Mount TBar

Secure the fixture to an appropriate structural support beam or hanger.

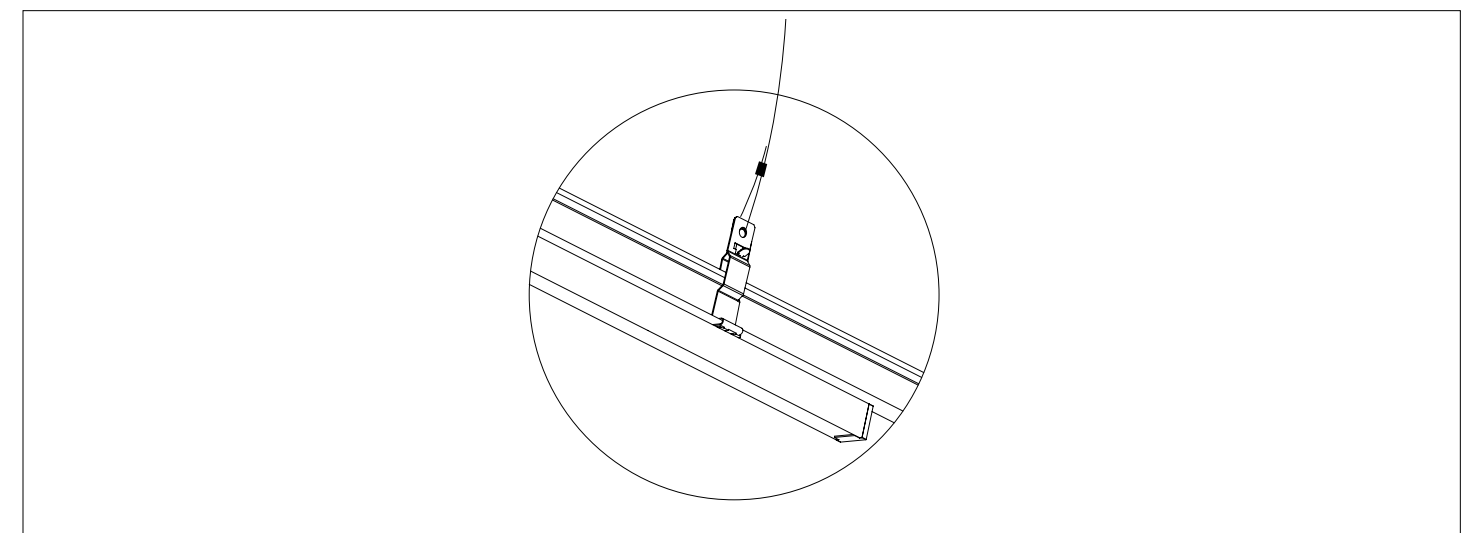

**STEP 5 — Final Installation** MICROSquare Surface Mount TBar

Locate and install the Remote Driver Box. Connect the fixtures DC cables to the Driver Box. Connect AC power to the Driver. Refer to the wiring diagram. Restore power.

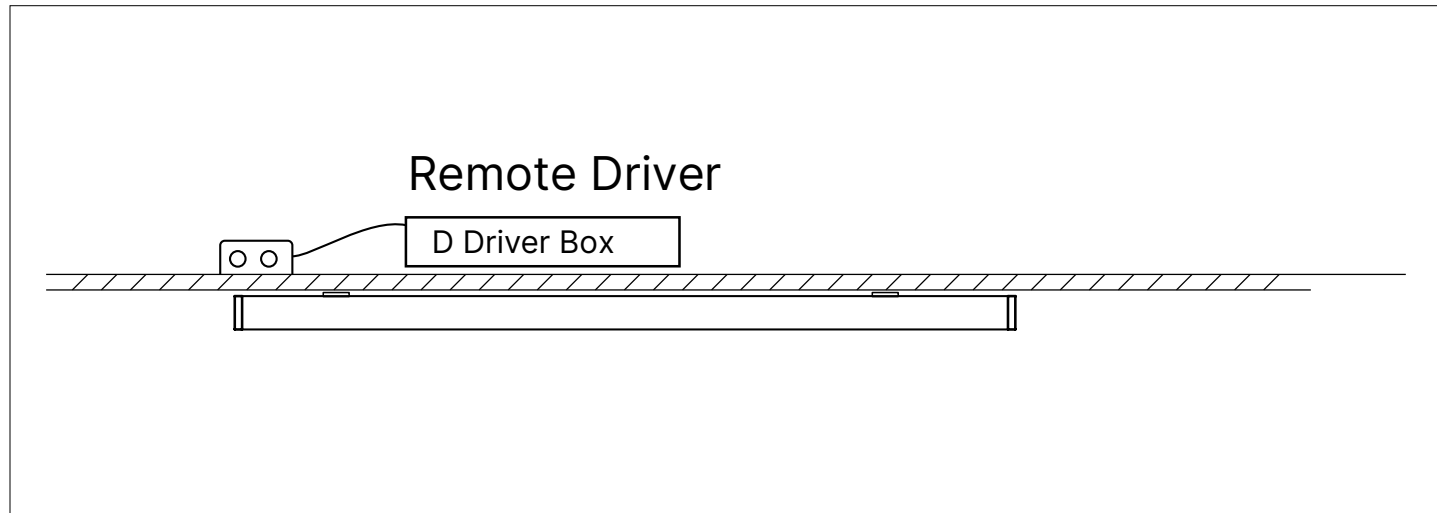

**Wiring Guide**

Wire the Power Feed End to the J-Box.

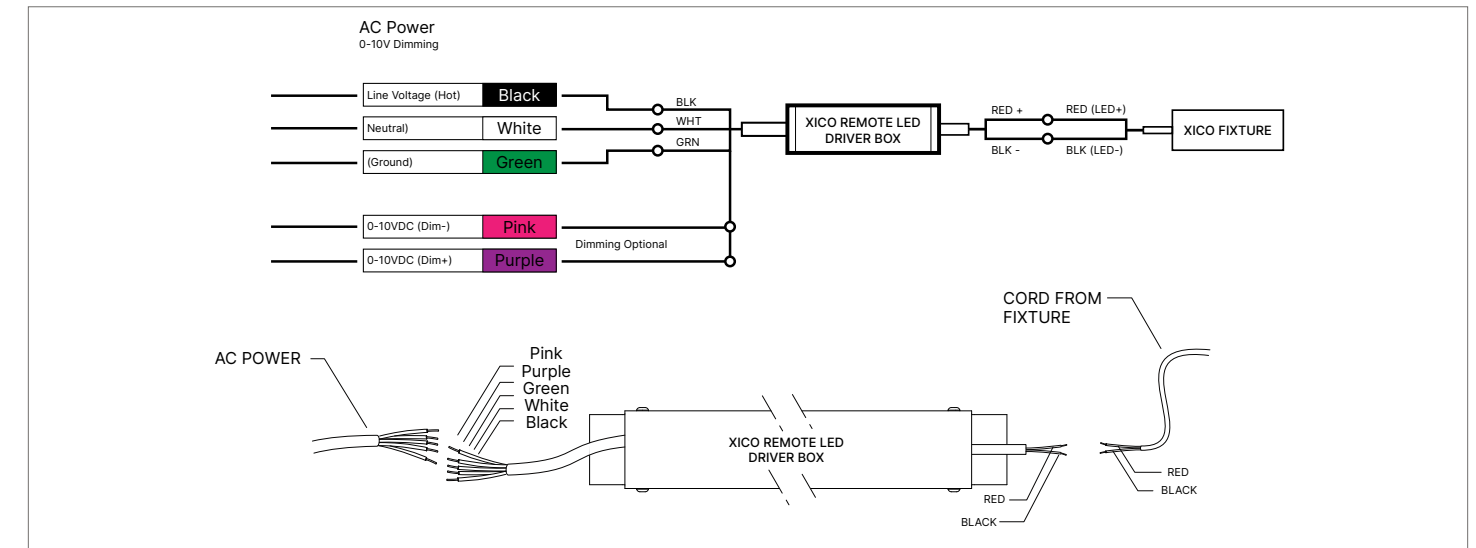

# Voltage Drop

## 24 VDC and Wire Length Chart (Driver to Fixture)

### XICO LED Fixture with Remote Drivers

When installing a XICO fixture with a remote driver and the distance is a long way from the fixture, it is important to properly specify the correct wire gauge (AWG/ or thickness of wire) for the distance of wire required. The maximum remote mounting distance is a function of the total voltage-drop across the output of the LED Driver.

### How to Use the Chart

- Step 1:** Calculate the total wattage of the LED lighting system (round up to the nearest 10 W).
- Step 2:** Find the wattage in the top row and follow the column down to maximum length (round up) of wiring between the LEDs and the power supply.
- Step 3:** Look to the left column for the wire gauge size required to prevent voltage drop over 3%.

Maximum Cable Length from Remote Driver to Fixture — 24 VDC Driver										
Wire Gauge	Total Fixture Wattage (W)									
	10 W	20 W	30 W	40 W	50 W	60 W	70 W	80 W	90 W	100 W
18 AWG	134 ft	68 ft	45 ft	33 ft	27 ft	22 ft	19 ft	17 ft	15 ft	14 ft
16 AWG	215 ft	109 ft	72 ft	54 ft	43 ft	36 ft	31 ft	27 ft	24 ft	22 ft
14 AWG	345 ft	174 ft	115 ft	86 ft	69 ft	57 ft	49 ft	43 ft	39 ft	36 ft
12 AWG	539 ft	272 ft	181 ft	135 ft	108 ft	90 ft	77 ft	68 ft	62 ft	56 ft
10 AWG	784 ft	397 ft	263 ft	197 ft	158 ft	131 ft	112 ft	98 ft	95 ft	82 ft

### Remote Driver to Fixture Example

**Calculate total load**

An 8 ft fixture using 4 W/ft requires a total of 32 W. Round up to the nearest load of 40 W.

**Find distance from driver to Load**

Let's assume the distance is 40 ft from the driver to the fixture. Round up to the nearest distance of 54 ft.

**Choose wire gauge**

It's recommended to install 16 AWG wire between the driver and fixture to eliminate noticeable voltage drop.